

DATA SHEET: TEMBREAK 2 ZS125-GJ MCCB WITH INTEGRAL RESIDUAL CURRENT PROTECTION (CBR)

MCCB Electrical Characteristics to IEC 60947-1, IEC 60947-2, IEC 60947-2 ANNEX B, IEC 60755

Frame Reference	Quantity	Unit	Condition	TB2 S125
Maximum In (A) of Frame				125
Model				ZS125
Number of Poles				3,4
Type				GJ
Nominal current ratings				
	I_n	(A)	50°C	20,32 50,63 100,125
Electrical characteristics				
Rated operational voltage	U_e	(V)	AC 50/60 Hz	525
Rated insulation voltage	U_i	(V)		525
Rated impulse voltage	U_{imp}	(kV)		8
Ultimate breaking capacity (IEC, JIS,AS/NZS)	I_{cu}	(kA)	525V AC 440V AC 400/415V AC 220/240V AC	25 50 65 85
Service breaking capacity (IEC, JIS,AS/NZS)	I_{cu}	(kA)	525V AC 440V AC 400/415V AC 220/240V AC	22 25 36/33 85
Energy withstand (EN 61008)	I^2t	(kA ² s)		>22.5
Peak current withstand (EN 61008)	I_{peak}	(A)		> 3.3
Protection				
Adjustable thermal, fixed magnetic Residual current protection, Type A Utilisation Category				■ ■ A
Installation				
Front Connection (FC)				■
Extension Bar (FB)				•
Cable Clamp (FW)				•
Rear Connection (RC)				•
Plug-in (PM)				-
Din Rail Mounting (DA)				•
Dimensions:	height	(mm)		155
	width	(mm)	3 pole 4 pole	90 120
	depth	(mm)		68
Weight	weight	(kg)	3 pole 4 pole	1.1 1.4
Operation				
Direct Opening Action				■
Toggle operation				■
Door mounted (HS)/ Breaker mounted handle (HB)				•
Motor operation				•
Residual Current Monitor and Remote Trip Module				•
Endurance	Electrical Mechanical	cycles cycles	415V AC	30,000 30,000

■ Standard • Optional - Not Available

DATA SHEET: TEMBREAK 2 ZS125-GJ MCCB WITH INTEGRAL RESIDUAL CURRENT PROTECTION (CBR)

Outline Dimensions ZS125-GJ

ASL: Arrangement Standard Line h_t : Handle Frame Centre Line

Front connected

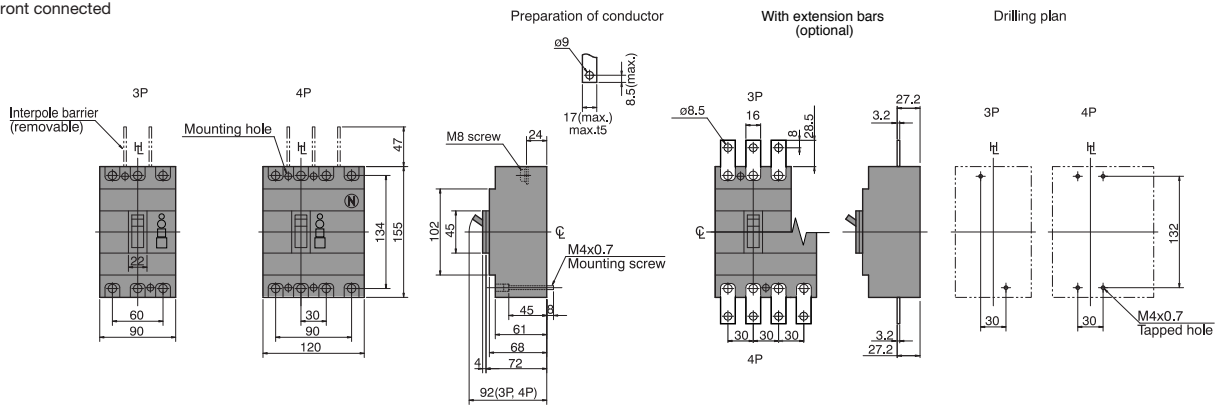

Rear connected

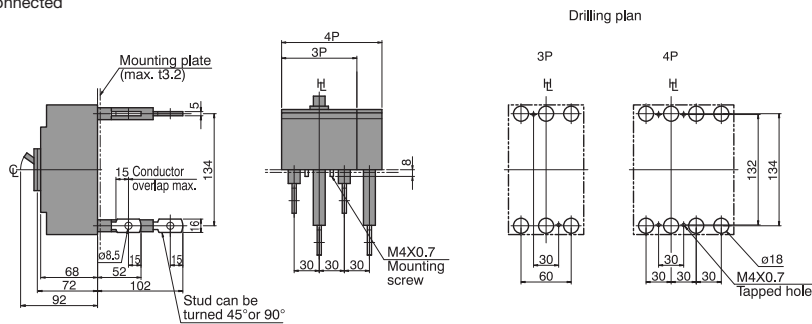

Panel cutout
(Front view)

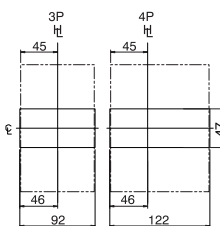

Panel cutout dimensions shown give an allowance of 1.0mm or more around the handle escutcheon.

DATA SHEET: TEMBREAK 2 ZS125-GJ MCCB WITH INTEGRAL RESIDUAL CURRENT PROTECTION (CBR)

Time/Current Characteristic Curves
ZS125-GJ,

Time/Current Characteristic Curves
ZS125-GJ

