

DATA SHEET: TEMBREAK 2 XS1600-ND MCCB FOR USE ABOVE 250V DC

MCCB Electrical Characteristics to IEC 60947-2, EN60947-2, JIS C 8201-2-1 ANN, 1

Frame reference	Quantity	Unit	Condition	TB 1600
Max In (A) of Frame				1600
Model				XS1600
Number of Poles				3
Type				ND
Nominal current ratings				
	I_n	(A)	50°C	1600
Electrical characteristics				
Rated insulation voltage	U_i	(V)	AC 50/60 Hz	690
Rated impulse voltage	U_{imp}	(kV)		8
Ultimate breaking capacity (IEC, JIS)	I_{cu}	(kA)	1000V DC①② 750V DC①② 600V DC①② 500V DC①② 350V DC①②	- 20 50 50
Service breaking capacity (IEC, JIS)	I_{cs}	(kA)	1000V DC①② 750V DC①② 600V DC①② 500V DC①② 350V DC①②	- - 15 25 25
Protection				
Fixed thermal, fixed magnetic				■
Adjustable thermal, fixed magnetic				
Magnetic trip only (adjustable)				
Installation				
Front connection (FC)				-
Extension bar (FB)				■
Rear connection (RC)				•
Plug-in (PM)				-
DIN rail mounting (DA)				-
Dimensions	height	(mm)	3 pole	370
	width	(mm)	4 pole	210
	depth	(mm)		-
	weight	(kg)	3 pole	140
			4 pole	27.0
Weight				-
Operation				
Direct Opening Action				■
Toggle operation				■
Breaker mounted (HB)				•
Door mounted (HS)				•
Motor operation				•
Endurance	Electrical	cycles	1000V DC 750V DC	- -
	Mechanical	cycles	350 - 600V DC -	500 2,500

① Connect all poles in series when over DC250V

② The time constant (L/R) of the circuit should be less than 2.0ms nearby rated current less than 5ms for short circuit < 10kA less than 10ms for short circuit < 20kA less than 15ms for short circuit > 20kA

DATA SHEET: TEMBREAK 2 XS1600-ND MCCB FOR USE ABOVE 250V DC

Outline Dimensions XS1600ND

ASL: Arrangement Standard Line Ht: Handle Frame Centre Line C: Handle Centre Line

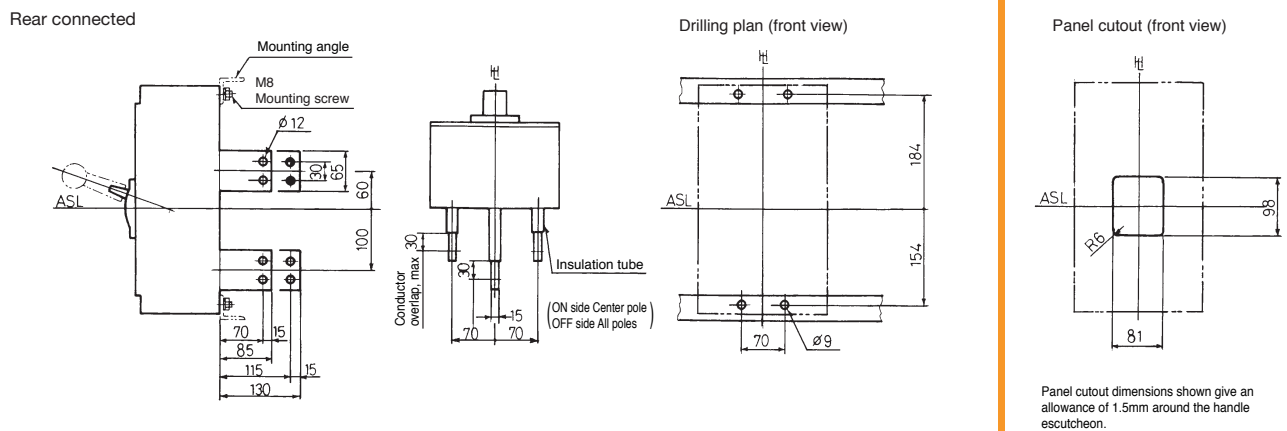
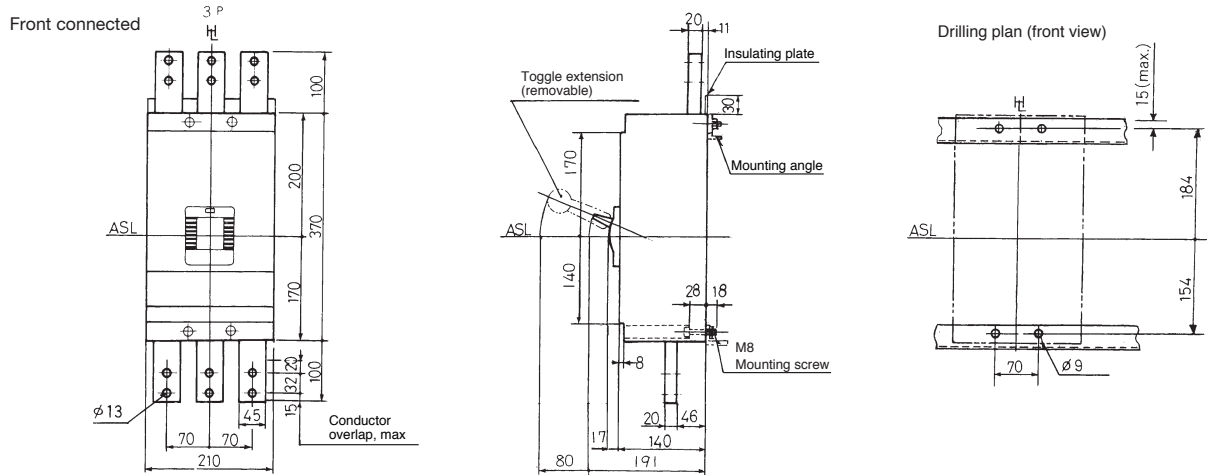

DATA SHEET: TEMBREAK 2 XS1600-ND MCCB FOR USE ABOVE 250V DC

Time/Current Characteristic Curves XS1600ND

