

DATA SHEET: TEMBREAK 2 S250-SJ MCCB

MCCB Electrical Characteristics to IEC 60947-2, EN 60947-2, JIS C 8201-2-1 ANN.1, NEMA AB-1

Frame Reference	Quantity	Unit	Condition	TB2 Lite 250
Max In (A) of Frame				250
Model				S250
Number of Poles				3, 4
Type				SJ
Nominal current ratings				
	I_n	(A)	50°C	160,200 250
Electrical characteristics				
Rated operational voltage	U_e	(V)	AC 50/60 Hz DC	690 250
Rated insulation voltage	U_i	(V)		800
Rated impulse voltage	U_{imp}	(kV)		8
Ultimate breaking capacity (IEC, JIS, AS/NZS)	I_{cu}	(kA)	690V AC	4
			525V AC	10
			440V AC	30
			400/415V AC	40
			220/240V AC	85
250V DC	25			
Service breaking capacity (IEC, JIS, AS/NZS)	I_{cs}	(kA)	690V AC	4
			525V AC	7.5
			440V AC	15
			400/415V AC	20
			220/240V AC	43
250V DC	13			
Rated breaking capacity (NEMA)		(kA)	480V AC 240VAC	25 85
Protection				
Fixed thermal, fixed magnetic				-
Adjustable thermal, adjustable magnetic				■
Utilisation category				A
Installation				
Front connection (FC)				■
Extension bar (FB)				•
Cable clamp (FW)				•
Rear connection (RC)				•
Plug-in (PM)				-
DIN rail mounting (DA)				-
Dimensions	height	(mm)		165
	width	(mm)	3 pole 4 pole	105 140
Weight	depth	(mm)		68
	weight	(kg)	3 pole 4 pole	1.5 1.9
Operation				
Direct Opening Action				■
Toggle operation				■
Door mounted (HS) / Breaker mounted handle (HB)				•
Motor operation				•
Endurance	Electrical	cycles	415V AC	6,000
	Mechanical	cycles		18,000

■ Standard • Optional - Not Available

DATA SHEET: TEMBREAK 2 S250-SJ MCCB

Outline Dimensions S250-SJ

ASL: Arrangement Standard Line H: Handle Frame Centre Line

Front connected

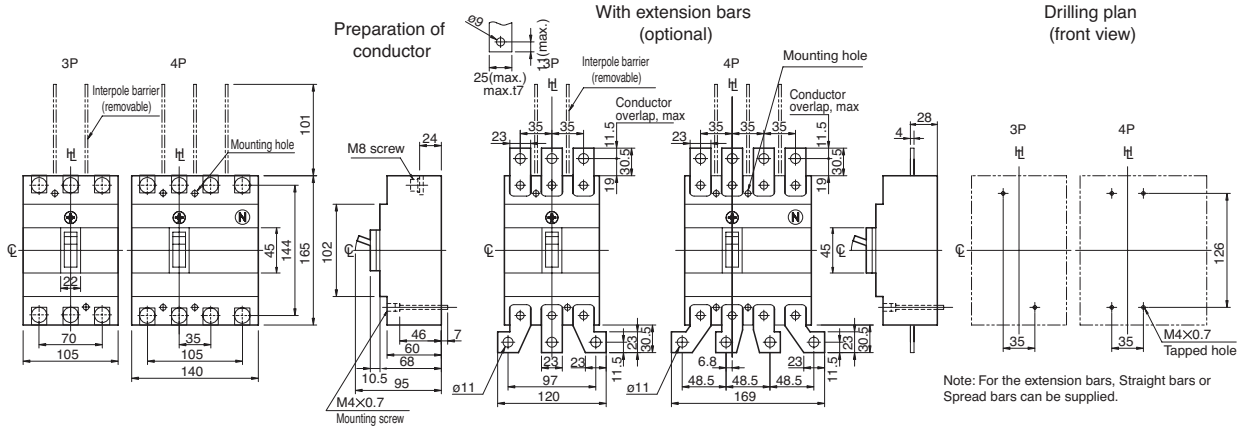

Rear connected

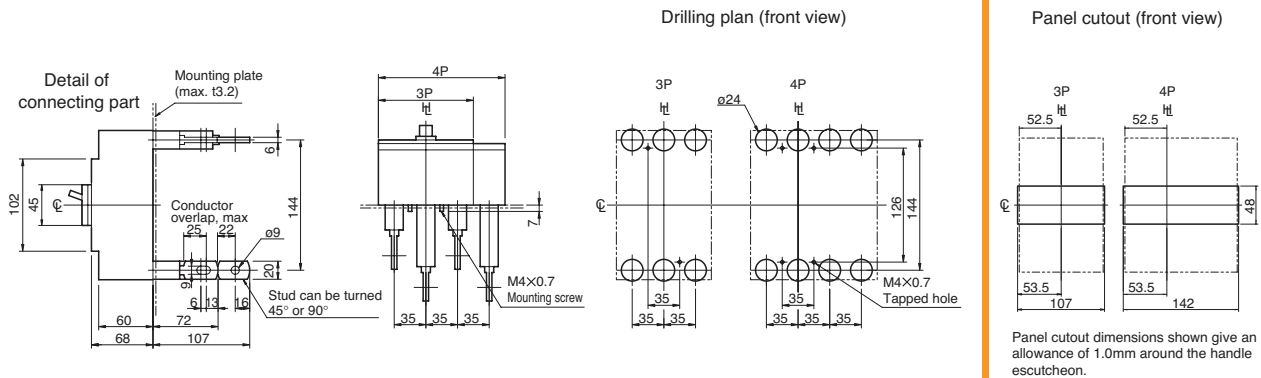

DATA SHEET: TEMBREAK 2 S250-SJ MCCB

Time/Current Characteristic Curves S250-SJ (100 ~ 200A)

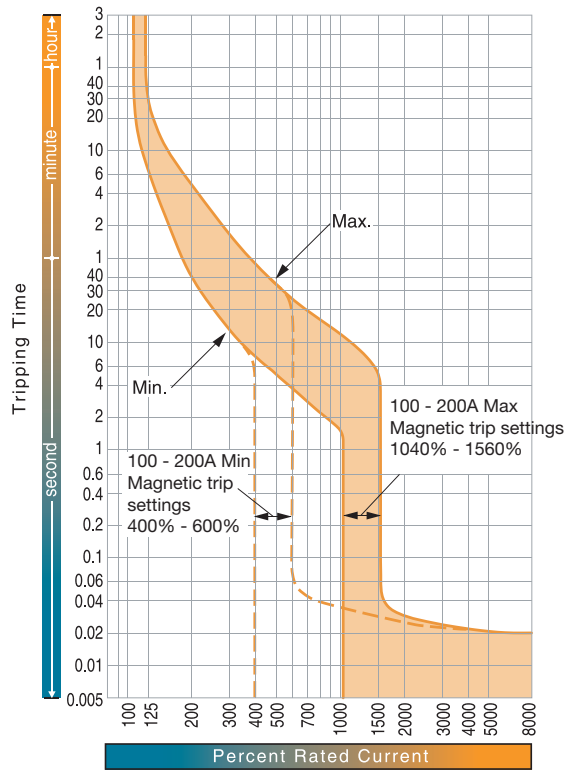

Time/Current Characteristic Curves S250-SJ (250A)

